

SE (Sem IV) EXTC (CG)

Control System

Q.P. Code : 546202

(3 Hours)

[Total Marks : 100

- N.B. : (1) Question No. 1 is compulsory.
 (2) Answer any four out of remaining six questions.
 (3) Figures to the right indicate full marks.
 (4) Assume suitable data if necessary.

1. Answer the following :-

20

- (a) Explain the concept of relative stability.
- (b) What do you mean by frequency domain analysis and explain the frequency domain performance indices.
- (c) Find out the T.F. of the given network.

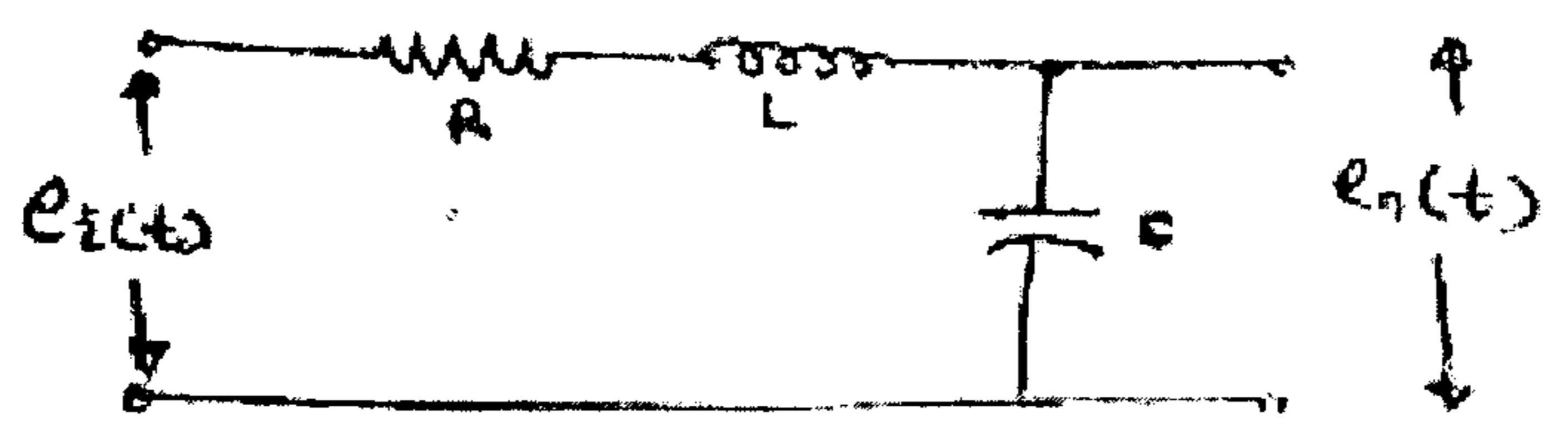

- (e) The forward path gain of a system is 2.5 and Pole-zero configuration of the system is shown below, find the overall transfer function and type of the system for unity feedback.

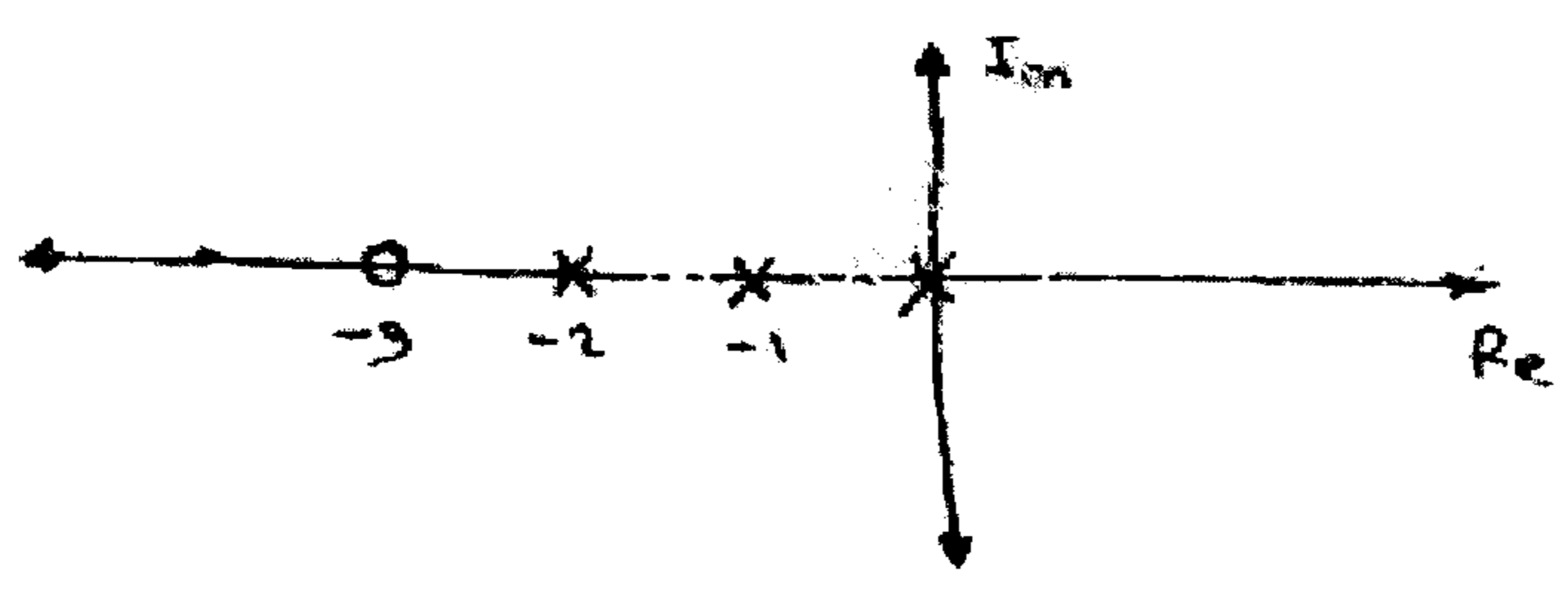

2. (a) Reduce the block diagram and obtain its transfer function.

10

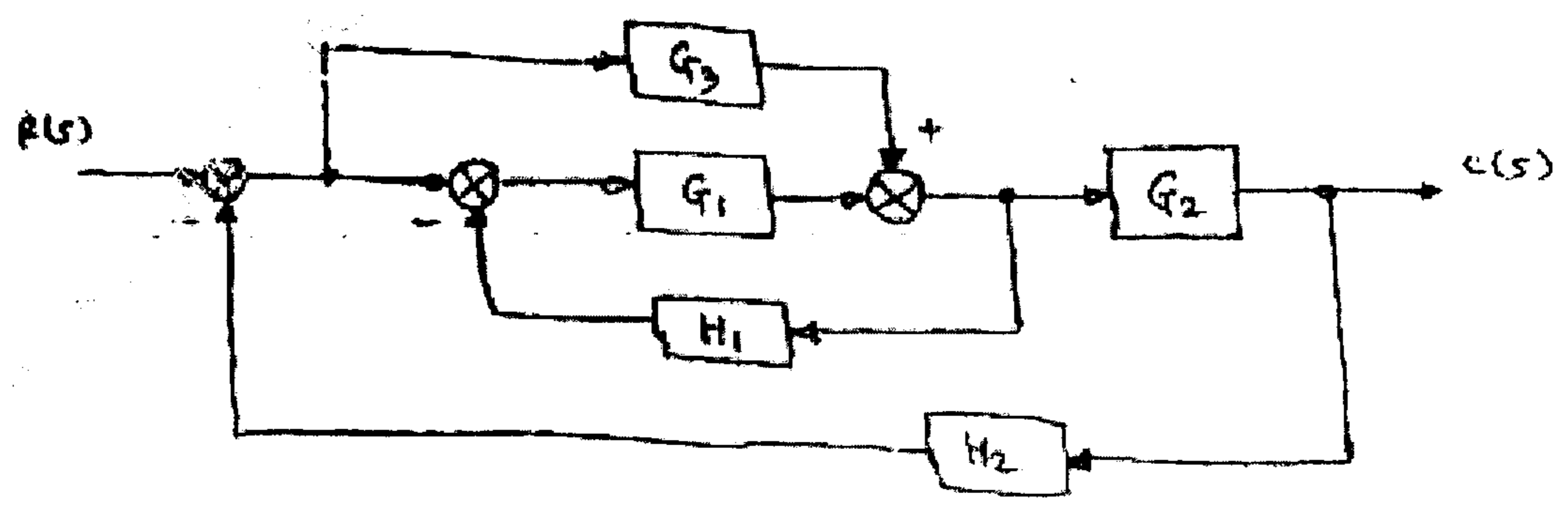

TURN OVER

- (b) Draw the corresponding signal flow graph of given block diagram and find $\frac{C(s)}{R(s)}$ 10

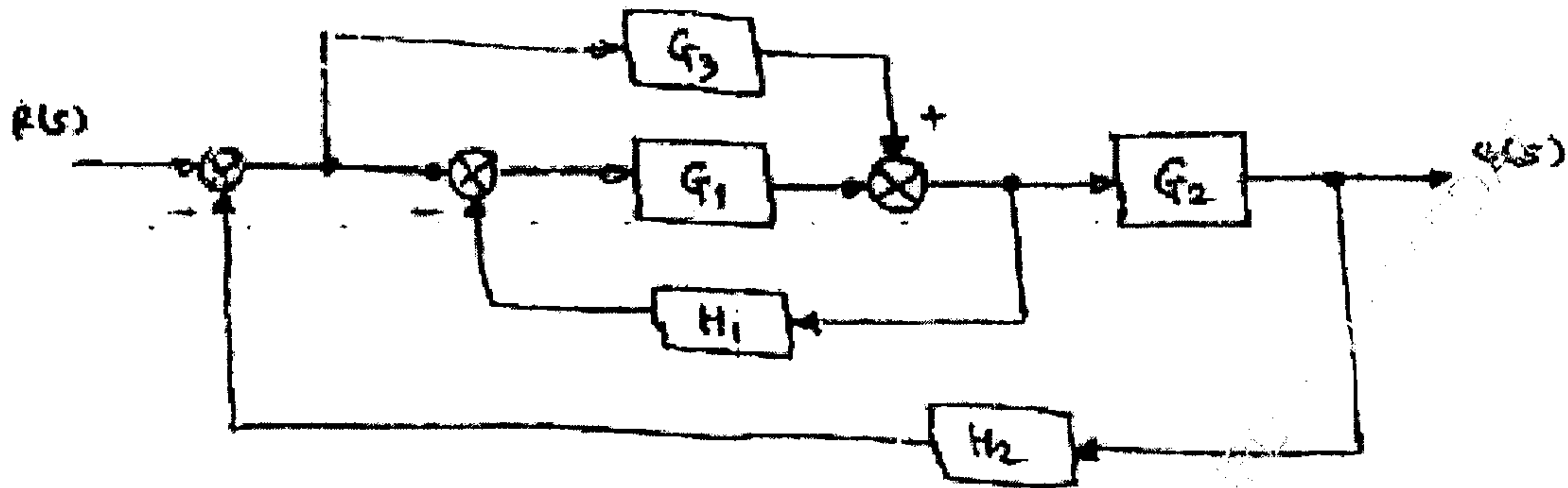

3. (a) State and prove properties of state transition matrix and check controllability and observability for the system. 10

$$\dot{x} = \begin{bmatrix} 0 & 6 & 5 \\ 1 & 0 & 2 \\ 3 & 2 & 4 \end{bmatrix} x - \begin{bmatrix} 0 \\ 1 \\ 2 \end{bmatrix} u$$

$$y = [1 \quad 3 \quad 0]x$$

- (b) A unity feedback system has - 10

$$G(s) = \frac{40(s+2)}{s(s+1)(s+4)}$$

- Determine : (i) Type of the system
(ii) All error coefficients
(iii) Error for ramp input with magnitude 4.

4. (a) Discuss the stability of the following systems for given characteristic equation using Routh-Hurwitz criterion. 10

(i) $s^6 + 4s^5 + 3s^4 + 16s^2 - 64s - 48 = 0$

(ii) $s^6 + 2s^5 + 8s^4 + 12s^3 + 20s^2 + 16s + 16 = 0$

- (b) A feedback control system has an open-loop transfer function. 10

$$G(S) = \frac{K}{S(S+3)(S^2 + 2S + 2)}$$

Find the root-locus as $k \rightarrow 0$ to ∞

SE (sem) IV EYTC

Q.P. Code : 546202

3

5. (a) For a particular unity feedback system, 10

$$G(S) = \frac{242(s - 5)}{s(s - 1)(s^2 - 5s - 121)}$$

Sketch the Bode plot and find W_{gc} , W_{pc} , G.M., P.M. and comment on stability.

- (b) For a certain control system 10

$$G(s).H(s) = \frac{K}{s(s + 2)(s + 10)}$$

Sketch the Nyquist plot and hence calculate the range of K for stability.

6. (a) Explain the frequency domain specifications. 20
(b) Explain the concept of Neuro-Fuzzy adaptive control system.
(c) Write short note on : Steady state errors in feed back control system and their types.
-

~~Web Programming~~
Signals and Systems
(3 Hours)

QP Code : 30797

[Total Marks : 80]

N.B.:

1. Question no.1 is compulsory
2. Attempt any three questions out of the remaining five.
3. Assume suitable data wherever necessary.

Q 1] Answer the following

[20]

a) Determine if the following system is memoryless, causal, linear, time invariant

$$y(t) = x^2(t-t_0) + 2$$

b) Explain in brief ROC (Region of Convergence) conditions of Laplace transform.

c) Consider two LTI systems connected in series. Their impulse responses are $h_1[n]$ and $h_2[n]$ respectively. Find the output of the systems if $x[n]$ is the input being applied to one of the systems.

$$x[n] = \{1, 2\} \quad h_1[n] = \{1, 0, -1\} \quad h_2[n] = \{2, 1, -1\}$$

d) State and prove time reversal property of Continuous time Fourier Series.

e) Find energy of a causal exponential pulse $x(t) = e^{-at}u(t)$ $a > 0$

Q 2] a) A DT signal is given by the following expression. Find its Z transform

[10]

$$x[n] = n\left(-\frac{1}{2}\right)^n u[n] * \left(\frac{1}{4}\right)^{-n} u[-n]$$

b) A CT signal $x(t)$ is applied to the input of a CT LTI systems with unit impulse response $h(t)$. Find out $y(t)$ using Convolution integral.

[10]

$$x(t) = e^{-at}u(t) \quad a > 0$$

$$h(t) = u(t)$$

Q3] a) Consider a causal LTI system with $H(j\omega) = \frac{1}{j\omega + 2}$. For a particular input $x(t)$, this systemproduces output $y(t) = e^{-2t}u(t) - e^{-3t}u(t)$. Find out $x(t)$ using Fourier Transform.

[10]

b) Obtain Inverse Laplace Transform of the function $X(s) = \frac{3s+7}{s^2-s-12}$ for following ROCs.

Also comment on the stability and causality of the system for each of the ROC conditions. Support your answer with appropriate sketches of ROCs.

[10]

i) $\text{Re}(s) > 4$

ii) $\text{Re}(s) < -3$

iii) $-3 < \text{Re}(s) < 4$

Q. 4] a) A DT signal has been shown. Sketch the following signals. [08]

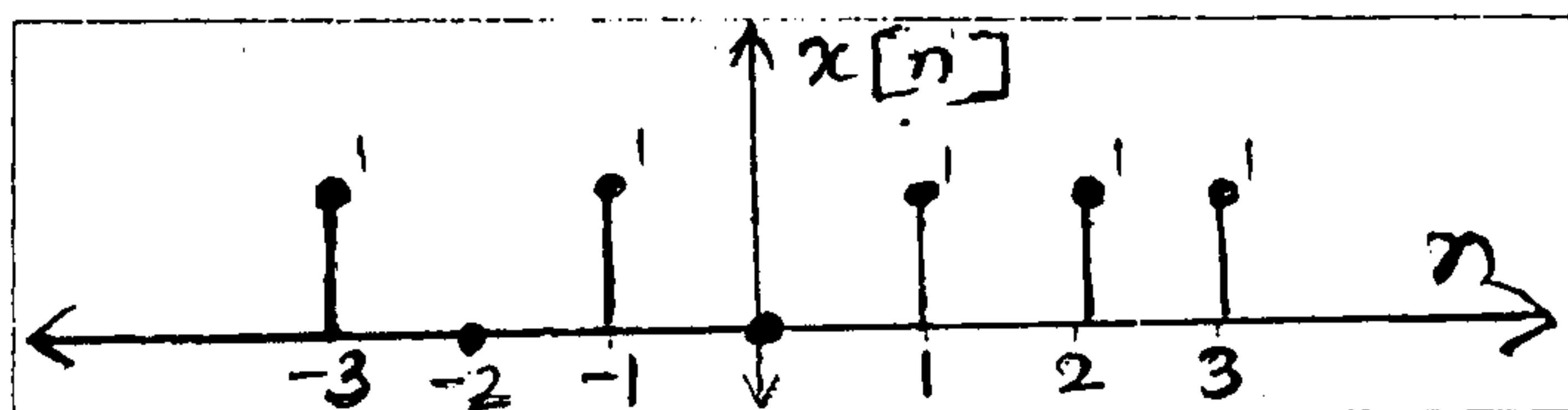

i) $x[n-4]$

ii) $x[4-n]$

iii) $x[-2n+2]$

iv) $x[n]u[3-n]$

b) Find out DTFT of the following [96]

i) $x[n] = \{1, -1, 2, 2\}$

ii) $x[n] = \sin\left[\frac{\pi n}{2}\right]u[n]$

QP Code : 30797

c) Determine inverse Z Transform of [06]

$$X(Z) = \frac{3}{(1-Z^{-1})(1+Z^{-1})(1-0.5Z^{-1})(1-0.2Z^{-1})}$$

Q5) a) Find the trigonometric Fourier Series for the waveform shown in the following figure. [10]

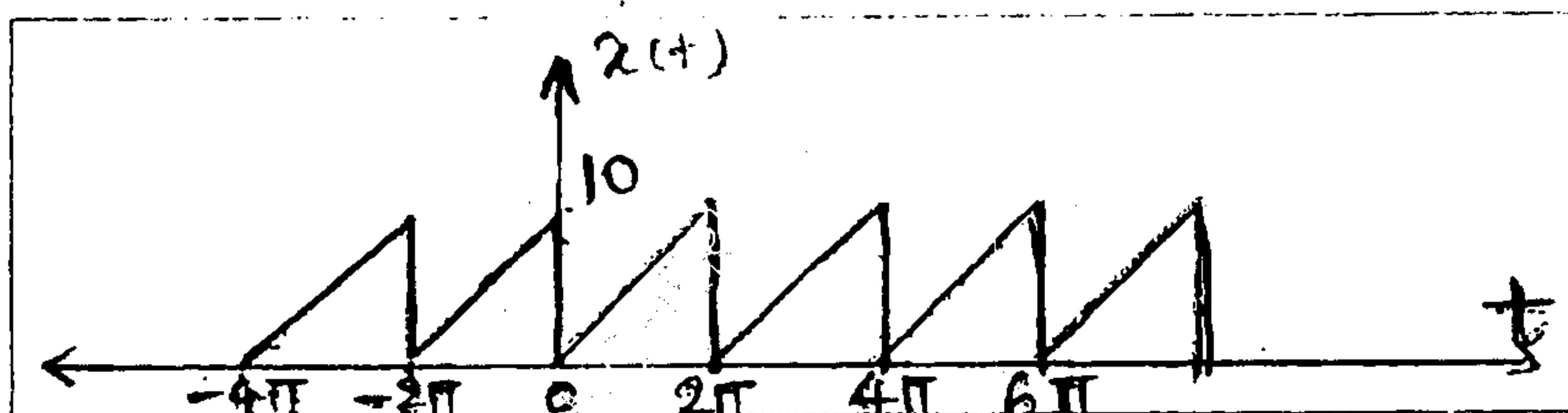

b) Determine impulse response of $h[n]$ for the system described by the second order difference equation. [10]

$$y[n] - 4y[n-1] + 4y[n-2] = x[n] - x[n-1] \text{ when } y[-1] = y[-2] = 0$$

Q6) a) A LTI system has the following transfer function [10]

$$H(Z) = \frac{Z}{\left(Z - \frac{1}{4}\right)\left(Z + \frac{1}{4}\right)\left(Z - \frac{1}{2}\right)}$$

i) Give all possible ROC conditions

ii) Show pole-zero diagram of a system

iii) Find impulse response of system

iv) Comment on the system stability and causality for all possible ROCs

b) Answer any two.

[10]

1) The Impulse response of DT system is given by $h[n]=\{1,2,3\}$ and the output response is given by $y[n]=\{1,1,2,-1,3\}$. Using Z transform, determine $x[n]$ by long division method.

2) Determine the autocorrelation of the CT signal given by $x(t)=A \operatorname{rect}\left(\frac{t}{2}\right)$.

3) For the following discrete time signals with a fundamental period of $N=6$, determine the Fourier Series Coefficients.

a) $x[n] = 1 + \cos\left(\frac{2\pi}{6}n\right)$

b) $y[n] = \sin\left(\frac{2\pi}{6}n + \frac{\pi}{4}\right)$

- N. B. :** (1) Question No.1 is **compulsory**.
(2) Attempt any **three** out of remaining questions.
(3) Use suitable data whenever is required.

1. Solve any **four** :-

20

- Describe significance of Boundary Conditions for Electric Field.
- Explain the operation of Electromagnetic Pump.
- Define Reflection and Transmission Coefficient.
- Compare parallel with perpendicular polarization.
- Define and explain Vector Magnetic Potential.

2. (a) Describe Poynting Theorem and explain various terms associated with the same

5

(b) Compare various numerical techniques such as FDM, FEM and MOM

5

(c) Obtain the Laplace's Equation for as infinitely long through whose cross section is shown in figure 1.

10

let $V_1 = 10\text{ V}$, $V_2 = 100\text{ V}$, $V_3 = 40\text{ V}$, $V_4 = 0\text{ V}$. USING ITERATION METHOD.

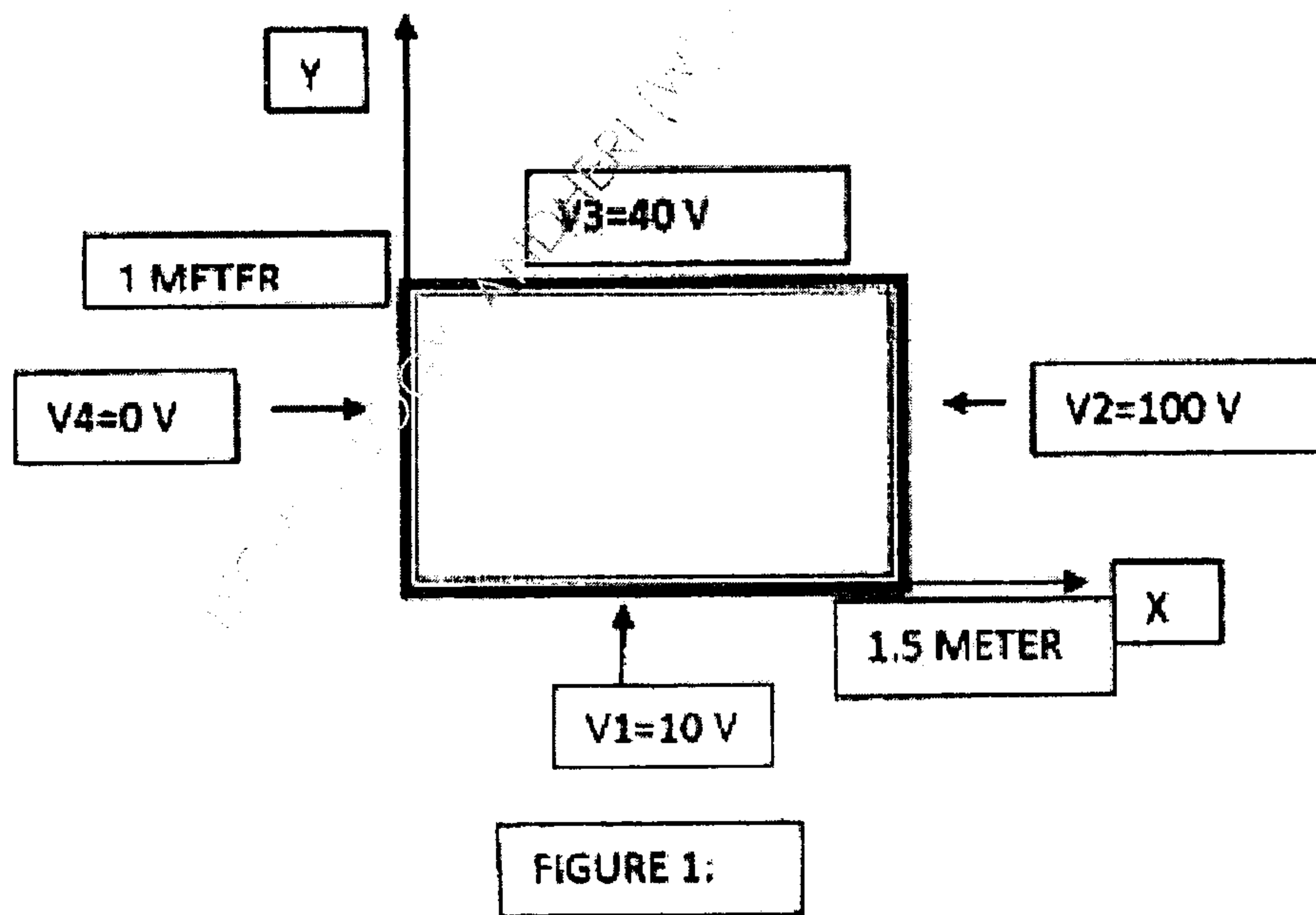

3. (a) A zero potential reference is at $r=10$ meter and point charge $Q=0.5$ nC is placed at origin. Find potential at $r=5$ meter and 15 meter. 5
- (b) Use MOM to find out the capacitance of parallel plate capacitor having plate area as 1×1 meter and distance between two plates is 1 meter. Assume air dielectric capacitor. Voltage across capacitor is 2 volts. 10
- (c) Derive the expression for magnetic field intensity due to infinite line conductor. 5
4. (a) Circular loop conductor carrying current of 1 A is placed in $x-y$ plane centred at origin. Find expression for Magnetic field intensity at any point P on Z- axis. 10
- (b) Four like charges of $40 \mu\text{C}$ each are located at four corners of a square. The square diagonal is 12 meters. Find the force on $200 \mu\text{C}$ charge located 5 meter above the centre of a square.- 10
5. (a) Define the following terms- 10
- 1) Wave Impedance
 - 2) Intrinsic Impedance
 - 3) Propagation Constant
 - 4) Attenuation Constant
 - 5) Phase Constant
- (b) In free space, $V=6xy^2z+8$. At point P (1,2,-5) find E and volume charge density. 10
6. (a) Describe the space wave propagation and derive relation for maximum distance between transmitting and receiving antenna. Earth is assumed to be flat. 10
- (b) Explain ducting effect. Under what conditions this effect takes place. 5
- (c) Describe the Fading. 5

Microprocessors & Peripherals.

Q.P. Code : 545902

(3 Hours)

[Total Marks :80

N.B. : (1) Q 1 is compulsory. Solve any 3 questions out of remaining

1. (a) Write features of Pentium microprocessor. 4
- (b) Differentiate between I/O mapped I/O and Memory Mapped I/O of 8086. 4
- (c) Describe in brief architecture of 8085 microprocessor. 4
- (d) Sketch read and write bus cycle of 8086 with example. 4
- (e) Explain in brief about programmable interval timer 8254. 4
2. (a) Describe the various addressing modes supported by 8086 with examples. 10
- (b) Explain with suitable examples the following instructions of 8086. 10
 - i) MOVSB ii) LEA iii) ROL iv) CLC v) CBW
3. (a) Write an assembly language program of 8086 to add two 32 bit numbers and also draw Flowchart. 10
- (b) Discuss the functions of general purpose registers of 8086. Explain the function of each register and instruction support for these functions. 10
4. (a) Describe the function of following pins in 8086 Microprocessor in maximum mode of operations. 10
 - 1) TEST 2) RQ/GTO 3) RQ/GT \bar{A} 4) QS0 and QS 1
 - 5) S0, S1, S2
- (b) Explain pin diagram of ADC 0808/0809 and method of interfacing to 8086 microprocessors with a suitable example. 10
5. Design 8086 microprocessor based system using minimum mode with the following specifications. 20
 - (i) 8086 microprocessors working at 10 MHz.
 - (ii) 128Kb EPROM using 32 k Devices.
 - (iii) 64 Kb SRAM using 16 k devices.

Clearly show memory map with address range. Draw the neat schematic.
6. (a) Explain 8086 interrupt structure and its method of interfacing with 8086 microprocessor with a suitable example. (any one interrupt) 10
- (b) Describe in brief and compare architecture of 80286 and 80486 microprocessors. 10

Q.P. Code : 545702

(3 Hours)

[Total Marks : 80

- N.B.:** (1) Question No.1 is compulsory.
(2) Solve **Any Three** questions from remaining **Five** questions.
(3) **Figures** to the **right** indicate **full marks**.
(4) Assume suitable **data** if **necessary** and mention the **same** in the **answer sheet**.

1. Solve any Five :

20

- (a) Define CMRR. Derive the expression for CMRR of a BJT differential amplifier.
(b) Draw the circuit diagram of an inverting amplifier using Op-Amp and derive expression for its voltage gain.
(c) Differentiate between small signal BJT and power BJT.
(d) For the circuit shown below find I_Q .

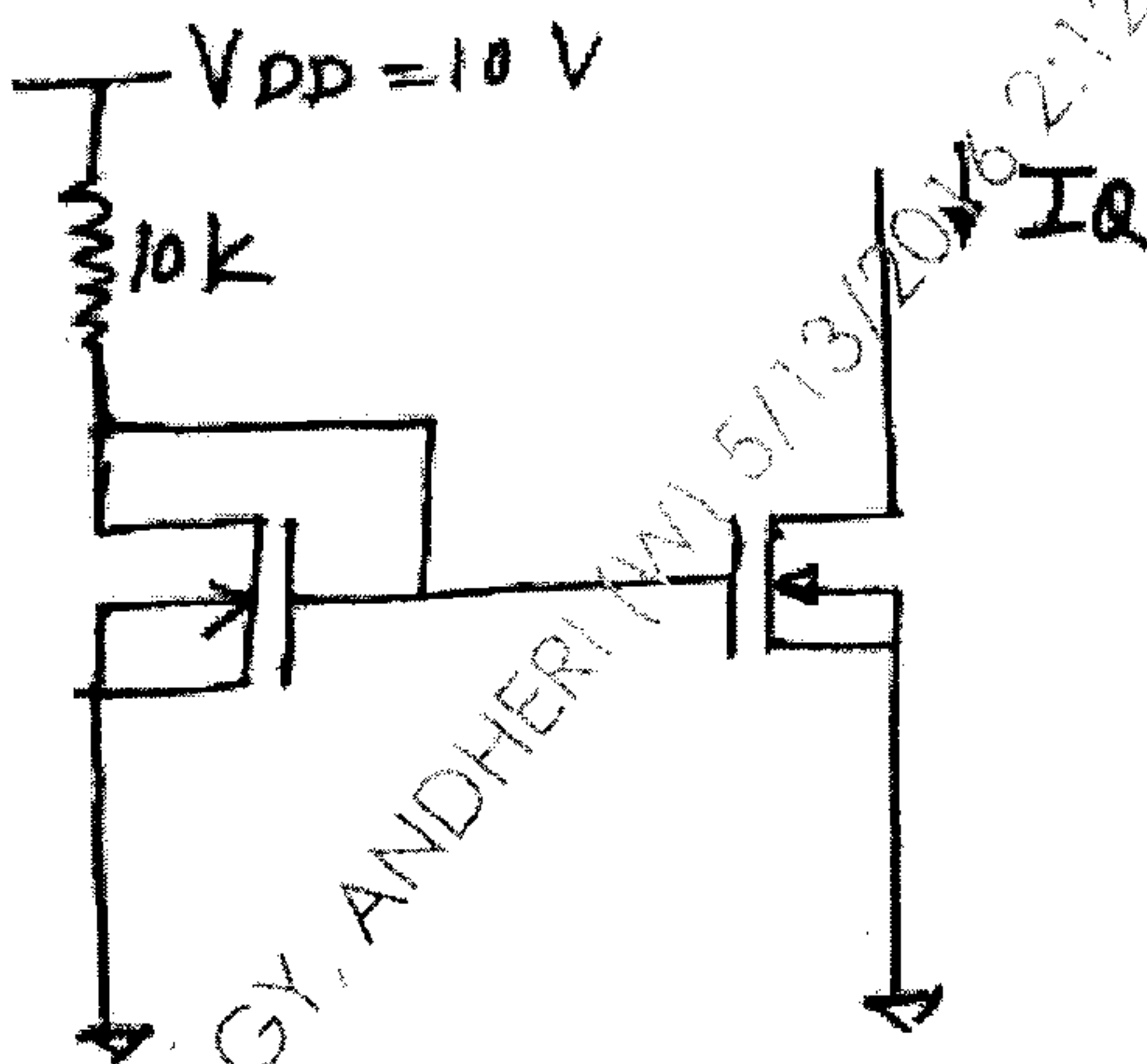

For both MOSFETS $V_{TN} = 1V$, $K_n = 100 \mu A/V^2$.

- (e) Explain working of Integrator using Op-Amp.
(f) For differential amplifier with $A_d = 100$ and $A_c = 0.1$. If two sets of inputs are applied as given below.
(i) $V_1 = 100 \mu V$, $V_2 = 80 \mu V$
(ii) $V_1 = 200 \mu V$, $V_2 = 160 \mu V$

Determine output voltage in each case.

TURN OVER

2. (a) Determine the corner frequency and maximum gain of the MOSFET amplifier 10 shown in figure.

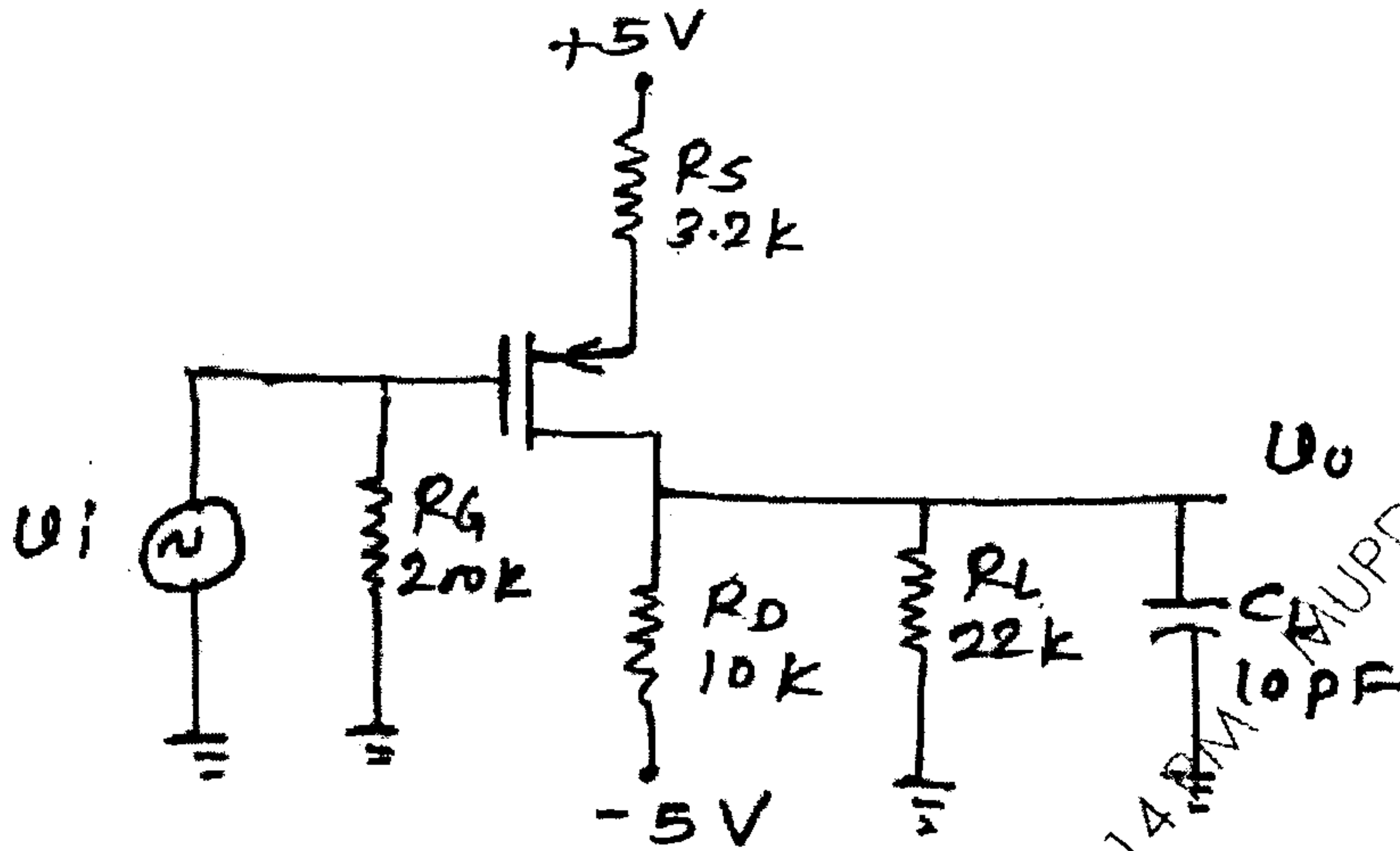

Fig. 2a

The transistor parameters are $V_{TP} = -2V$, $K_n = 0.25 \text{ mA/V}^2$ and $\lambda = 0$.

- (b) For the circuit in Fig. 2b, Find midband gain and corner frequencies. 10

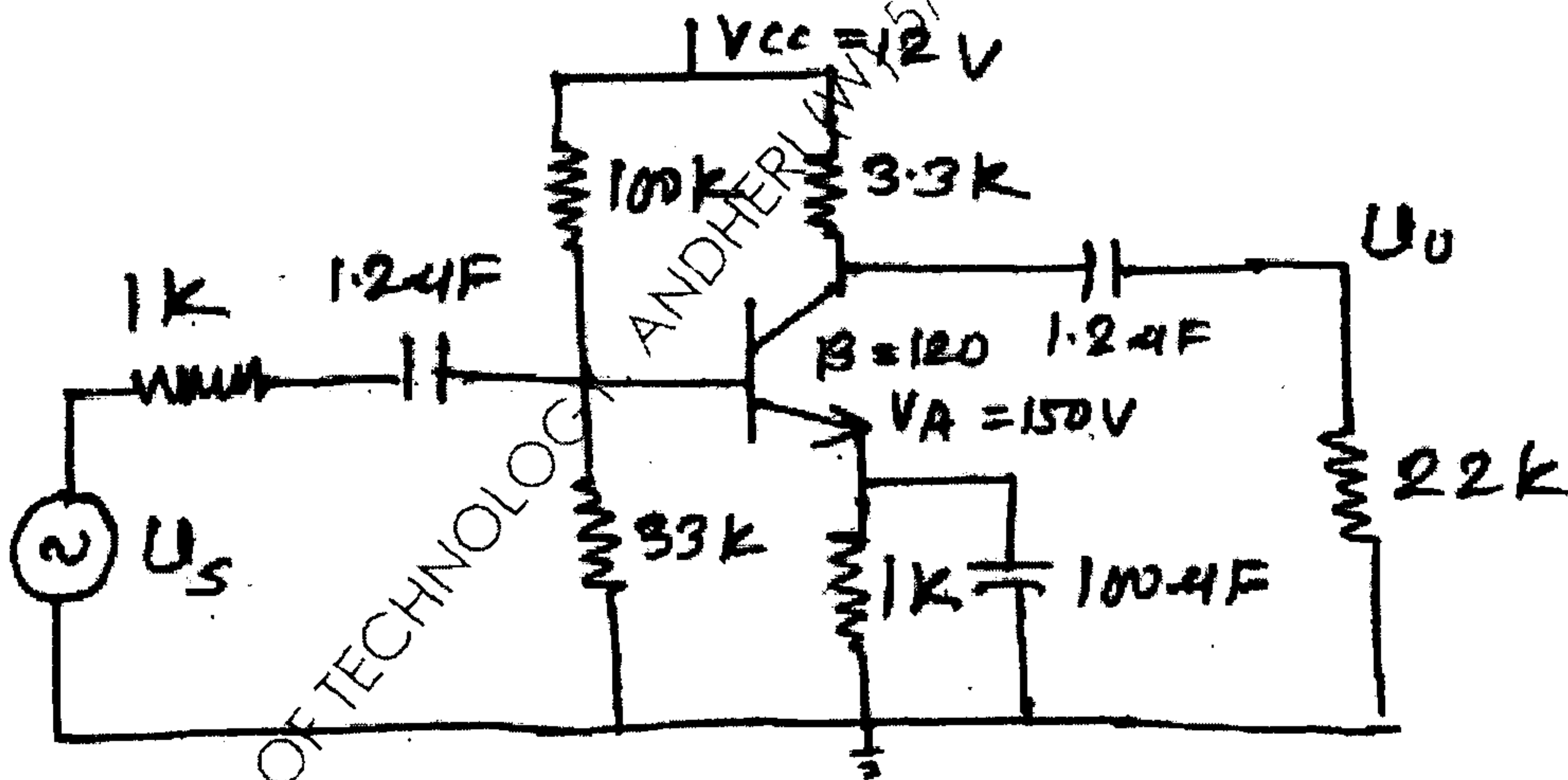

Fig. 2b

TURN OVER

MUPD16448 SARDAR PATEL INSTITUTE OF TECHNOLOGY

3. (a) The cascode circuit shown in Fig. 3a has parameters $V^+ = 12V$, $V^- = 0V$, $R_1 = 58.8k\Omega$, $R_2 = 33.3k\Omega$, $R_3 = 7.92k\Omega$, $R_C = 7.5k\Omega$, $R_S = 1k\Omega$, $R_E = 0.5k\Omega$ and $R_L = 2k\Omega$. The transistor parameters are $\beta = 100$, $V_{BE} = 0.7V$, $V_A = \infty$, $C_\pi = 24pf$ and $C_u = 3pf$. 10

- (i) Determine upper 3dB frequencies corresponding to the input and output portions of the equivalent circuit.
- (ii) Calculate small signal midband voltage gain.

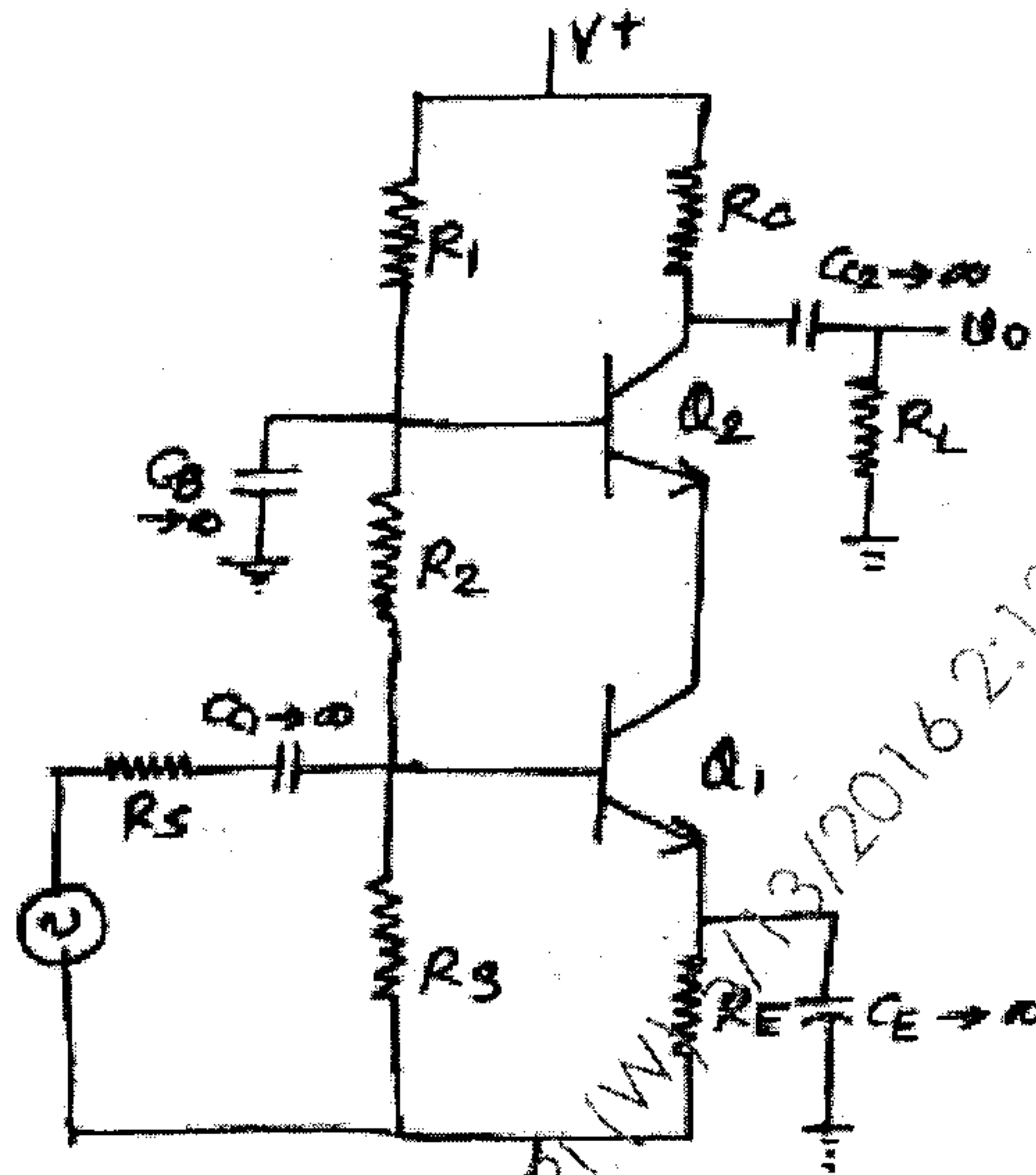
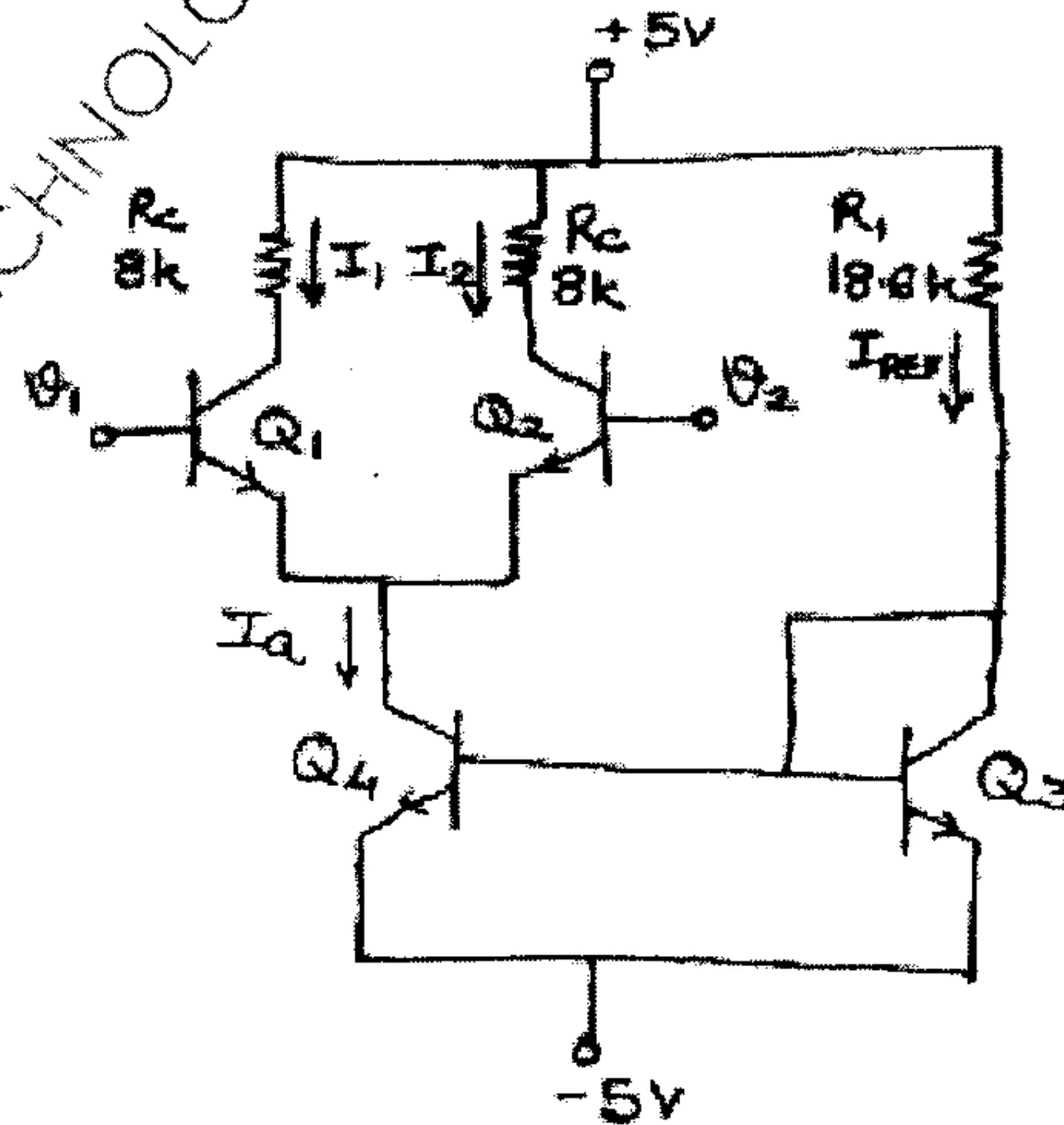

Fig. 3a

(b) Determine the differential and common-mode input resistances of a differential amplifier shown in figure below : 10



The transistor parameters are $V_{BE(ON)} = 0.7V$, $\beta = 100$ and $V_A = 100V$.

TURN OVER

MUPD16448 SARDAR PATEL INSTITUTE OF TECHNOLOGY MUPD16448 SARDAR PATEL INSTITUTE OF TECHNOLOGY MUPD16448 SARDAR PATEL INSTITUTE OF TECHNOLOGY

4. (a) Draw a neat circuit diagram and explain working of the improved 3 transistor (MOSFET) current source. Derive the relationship between the output current and reference current. **10**
- (b) Draw the circuit diagram for an inverting summing amplifier using operational amplifier. Derive the relationship for its output voltage V_0 for four inputs V_1, V_2, V_3 and V_4 . **10**
5. (a) Explain Class - B operation of power amplifiers. What is crossover distortion? How is it eliminated. **10**
- (b) For the circuit shown in fig. 5b, the transistor parameters are $\beta = 100$, $P_{D\text{MAX}} = 2.5 \text{ W}$, $V_{CE\text{MAX}} = 25\text{V}$, $I_{C\text{MAX}} = 500\text{mA}$. If $R_L = 100\Omega$ then find V_{CC} and R_B to deliver maximum power to the load. With the obtained values of V_{CC} and R_B calculate the maximum undistorted ac power that can be delivered to R_L . **10**

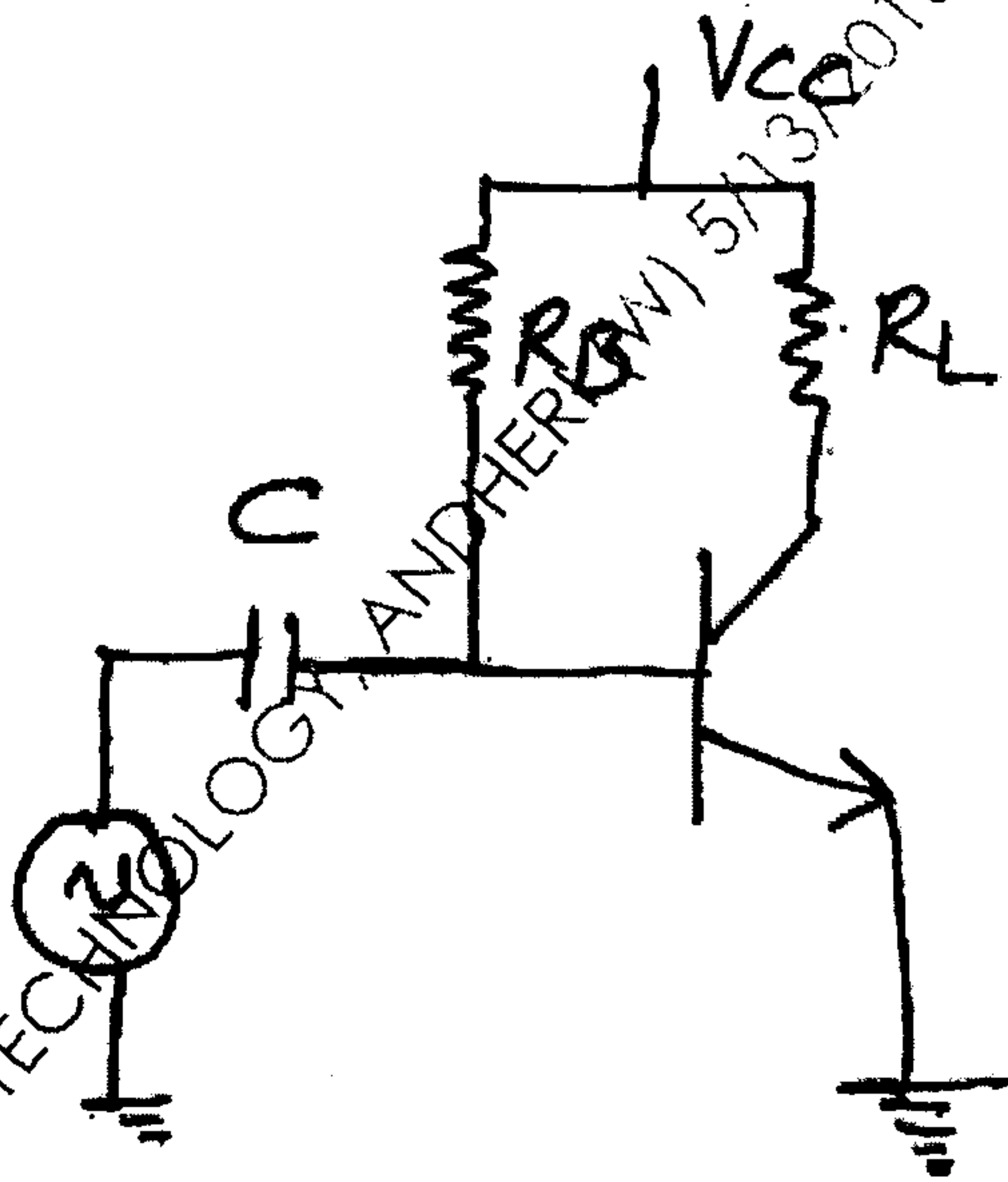

6. Write short notes on any Four :

20

- (a) Zener Shunt Regulator
- (b) Power MOSFET
- (c) Active Filters
- (d) Multistage Amplifiers
- (e) Millers Theorem.

(3 Hours)

[Total Marks: 80

- N.B.:** (1) Question No.1 is compulsory.
 (2) Attempt any Three from the remaining.

1. (a) Find the extremal of the functional

$$\int_0^1 [y'^2 + 12xy] dx \text{ subject to } y(0) = 0 \text{ and } y(1) = 1.$$

- (b) Verify Cauchy - Schwartz inequality for $u = (1, 2, 1)$ and $v = (3, 0, 4)$ also find the angle between u & v . 5

- (c) If λ & X are eigen values and eigen vectors of A then prove that $\frac{1}{\lambda}$ and X are eigen values and eigen vectors of A^{-1} , provided A is non singular matrix. 5

- (d) Evaluate $\int_C \frac{e^{2z}}{(z+1)^4} dz$ where $C : |z| = 2$ 5

2. (a) Find the extremal that minimises the integral 6

$$\int_{x_0}^{x_1} (16y^2 - y'^2) dx$$

- (b) Find eigen values and eigen vectors of A^3 6

where $A = \begin{bmatrix} 2 & 1 & 1 \\ 2 & 3 & 2 \\ 3 & 3 & 4 \end{bmatrix}$

- (c) Obtain Taylor's and two distinct Laurent's expansion of $f(z) = \frac{z-1}{z^2-2z-3}$ 8
 indicating the region of convergence.

[TURN OVER

- 2 -

3. (a) Verify Cayley-Hamilton Theorem for 6

$$A = \begin{bmatrix} 2 & -1 & 1 \\ -1 & 2 & -1 \\ 1 & -1 & 2 \end{bmatrix} \text{ and hence find } A^{-1}$$

- (b) Using Cauchy Residue Theorem, evaluate 6

$$\int_{-\infty}^{\infty} \frac{x^2 - x + 2}{x^4 + 10x^2 + 9} dx$$

- (c) Show that a closed curve 'C' of given fixed length (perimeter) which encloses maximum area is a circle. 8

4. (a) Find an orthonormal basis for the subspace of \mathbb{R}^3 by applying Gram-Schmidt process where $S = \{(1,1,1), (0,1,1), (0,0,1)\}$. 6

- (b) Find A^{50} , where 6

$$A = \begin{bmatrix} 2 & 3 \\ -3 & -4 \end{bmatrix}$$

- (c) Reduce the following Quadratic form into canonical form & hence find its rank, index, signature and value class where, 8

$$Q = 3x_1^2 + 5x_2^2 + 3x_3^2 - 2x_1x_2 - 2x_2x_3 + 2x_3x_1$$

5. (a) Using the Rayleigh-Ritz method, find an approximate solution for the 6

extremal of the functional $\int_0^1 \{xy + \frac{1}{2}y'^2\} dx$ subject to $y(0) = y(1) = 0$.

- (b) Prove that $W = \{(x,y) | x = 3y\}$ subspace of \mathbb{R}^2 . Is $W_1 = \{(a,1,1) | a \text{ in } \mathbb{R}\}$ subspace of \mathbb{R}^3 ? 6

[TURN OVER

- (c) Prove that A is diagonalizable matrix. Also find diagonal form and transforming matrix where 8

$$A = \begin{bmatrix} 1 & -6 & -4 \\ 0 & 4 & 2 \\ 0 & -6 & -3 \end{bmatrix}$$

6. (a) By using Cauchy Residue Theorem, evaluate $\int_0^{2\pi} \frac{\cos^2 \theta}{5 + 4 \cos \theta} d\theta$. 6

- (b) Evaluate $\int_C \frac{z+4}{z^2+2z+5} dz$ where $C : |z+1+i|=2$. 6

- (c) (i) Determine the function that gives shortest distance between two given points. 5

- (ii) Express any vector (a,b,c) in R^3 as a linear combination of v_1, v_2, v_3 where v_1, v_2, v_3 are in R^3 . 3
